

SpecBright™

LED Area Lights



Extremely bright LED illumination designed for the most demanding applications

ProPhotonix SpecBright LED Arealights are the brightest LED illuminators in their class. Manufactured with a high LED packing density and excellent thermal management, SpecBright LED Arealights offer several times the brightness of LED illuminators fabricated with packaged LEDs for modules of comparable size.

SpecBright Arealights combine up to 100 individually mounted LED chips with an aspherically corrected lens to produce a bright, highly uniform beam. These compact units provide the high-power illumination required in machine vision, biomedical, fluorescence, and strobing applications.

SpecBright Arealights are available in a wide range of wavelengths and with various divergence angles. They can be operated in continuous (CW) or pulsed mode. A backlight configuration is also available where the standard lens is replaced with a diffuser. Custom solutions are also available to meet different optical or mechanical requirements.



Key Features

- Extremely bright & compact
- Superior uniformity
- Chip-on-board technology
- Seamless integration and mounting
- UV, visible, and near-IR

Applications

- Machine vision
- Fluorescence spectroscopy
- UV tracing
- UV curing

Accessories

- Power supplies
- Current mode drivers
- Heat sinks
- Strobe drivers

Options

- UV, visible, near-IR and white
- CW or pulsed mode
- Backlight or Frontlight

Spectral Characteristics

Colour	UV	UV	Blue	Red	IR	IR
Peak wavelength (nm)	370 ± 10	395 ± 10	470 ± 10	630 ± 10	740 ± 10	870 ± 10
Spectral width FWHM (nm)	11	14	30	16	29	46

Illumination Characteristics^{1,2}

	UV (370)	UV (395)	Blue (470)	Red (630)	IR (740)	IR (870)
AF1						
Divergence angle (degrees)	± 7.7	± 8.5	± 8.8	± 9.2	± 10.1	± 9.9
Illumination diameter FWHM at working distance of 100mm (mm)	46.5	47.5	49	49	53	53
Irradiance at 100mm (W/m ²)	106	78	180	228	124	168
Illuminance at 100mm (klux)	N/A	N/A	17	46.1	N/A	N/A
AF2						
Divergence angles (degrees)	± 16.4	±16	± 15.7	± 15.8	± 16.8	± 16.8
Illumination diameter FWHM at working distance of 100mm (mm)	83	81	80.5	81	84	83
Irradiance at 100mm (W/m ²)	43	33	81	104	61	83
Illuminance at 100mm (klux)	N/A	N/A	7.6	21	N/A	N/A

1 See Figures 1 and 2 for graphs of FWHM illumination diameter and irradiance, as a function of working distance for the red arealight. Irradiance, Illuminance and linewidth of Blue, UV and IR units, for working distance other than that shown above may be computed with reference to the Intensity vs Working Distance and Beam Width vs Working Distance plots provided for the red arealight. Values computed in this manner are valid within ±5%
 2 Irradiance and Illuminance are measured at the centre of the illumination field, in continuous wave mode at maximum operating current (current mode)

Electrical Characteristics, Lifetime & Environment^{3,4}

AF1	UV (370)	UV (395)	Blue (470)	Red (630)	IR (740)	IR (870)
Voltage mode (code "V") Operating current (mA) at 24V	360	360	200	200	200	200
Current mode (code "I") Maximum operating current (mA)	400	400	400	400	400	400
Mean time before failure (MTBF)	60,000	60,000	60,000	60,000	60,000	60,000

3 Case temperature should not exceed 45°C.

4 MTBF is defined as the time before LED output intensity falls to 70% of maximum

Illumination Characteristics

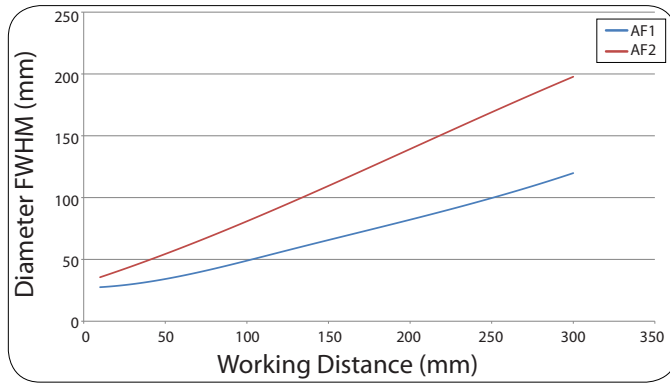

Figure 1 - Diameter of field of illumination vs. working distance for AF1-630 (narrow beam) and AF2-630 (wide beam).

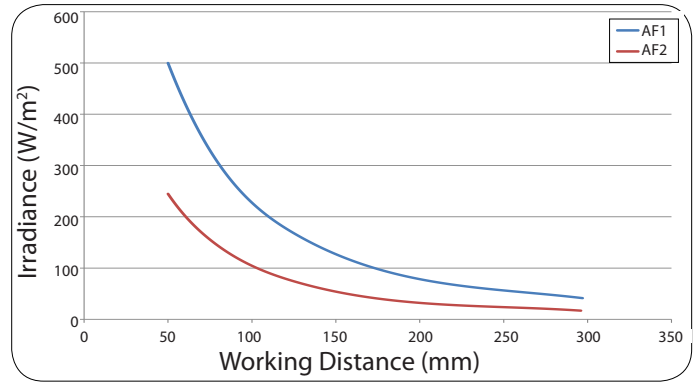

Figure 2 - Irradiance vs. working distance for AF1-630 (narrow beam) and AF2-630 (wide beam) measured at maximum operating current (current mode).

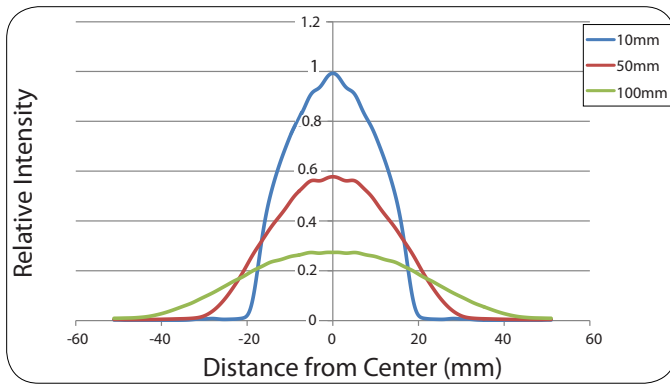

Figure 3 - Intensity profile for AF1-630. Working distances (WD) of 10, 50, and 100 mm.

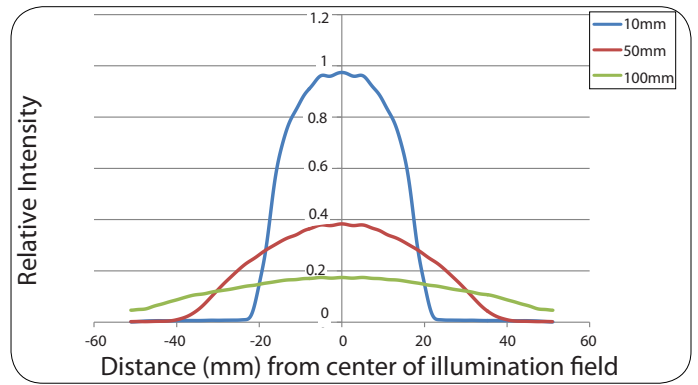

Figure 4 - Intensity profile for AF2-630. Working distances (WD) of 10, 50, and 100 mm.

Note: All measurements were made in continuous (CW) mode.

Part Numbers

Product Code	Frontlight	Series	Wavelength	Voltage or Current Source	Without or with Heat Sink	Connector or Flying Leads	Cable Length (in cm)
A	F or B	1 or 2	370	V or I	X or H	C or F	100 (standard)
			395				
			470				
			630				
			740				
			870				

Example: AF1-630-VXC100.

Custom Solutions

ProPhotonix specializes in providing customized solutions. Please enquire for other wavelengths, powers, optics, or mechanics.

Connectors / Flying Leads

- Tyco Mini Universal Mate-N-Lok connectors are available for 24VDC voltage configured lights (i.e. P/N AF1-630-VXF100) and can be paired with the connectorized AC power adaptor (P/N PTS400-24C) for lab or bench top use. They provide a secure locking mechanism and reverse polarity protection.
- Flying leads are standard for current source (I) modules.

Power Supplies

We offer both universal AC-mains to 24VDC power (2W/500mA) adaptors and standard industrial 24VDC (240W/10A) switching power supplies (P/N PSU-24V-240W). The power adaptors are offered with connectors (P/N PTS400-24C) for easy connection with optionally connectorized lights or as flying leads (P/N PTS400-24F) for use with the CMP or application specific connections. Interchangeable plugs are included for use in any country.

Heat Sinks

Ensure the housing temperature does not exceed 45°C. Heat sinking is highly recommended when LED lights are used at or near full power in continuous, high duty cycle, or long pulse width applications. In absence of a customer provided heat sink or mounting structure, ProPhotonix offers optimized heat sinks for use with our lights.

Heat Sink

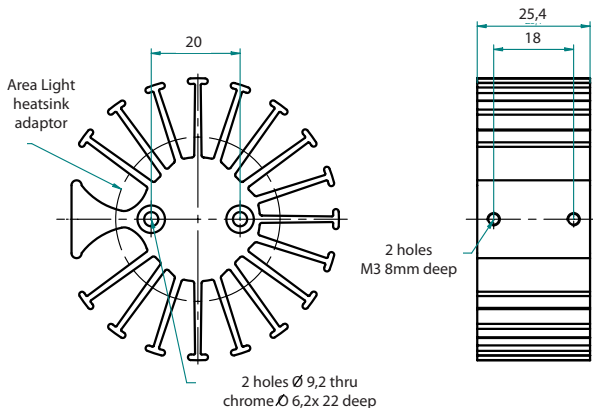

Area light heatsink adaptor included with Heatsink

Controllers & Strobe Drivers

The Current Mode Power (CMP) controller drives SpecBright™ LED Illuminators, both constant current and 24VDC configured options. The CMP is a compact, DIN rail mountable controller requiring only 24VDC input (500-mA min) for easy integration. It features both manual intensity control—via a potentiometer—and remote control via analog inputs for intensity adjustment and a TTL input for fast, repeatable non-overdriven on/off/strobe control. The SpecBright™ CMS series of LED Controllers and strobe drivers provide precise deterministic LED control for both continuous, intermittent, and highly over driven strobing applications. These are multi independent channel controllers that have flexible power input requirements and have current outputs in 5-mA increments up to several Amps continuous and up to 20 Amps pulsed. They feature push button manual control or communication via Ethernet or RS-232 for sophisticated integration needs. For high speed applications where motion must be stopped over-driving LEDs can produce as many as 10-20x the light output for a short pulse time—generally 1msec or less—and small duty cycles—generally 10% or less. Overdriving is performed at your own risk. Please enquire for assistance.

Dimensional Diagrams

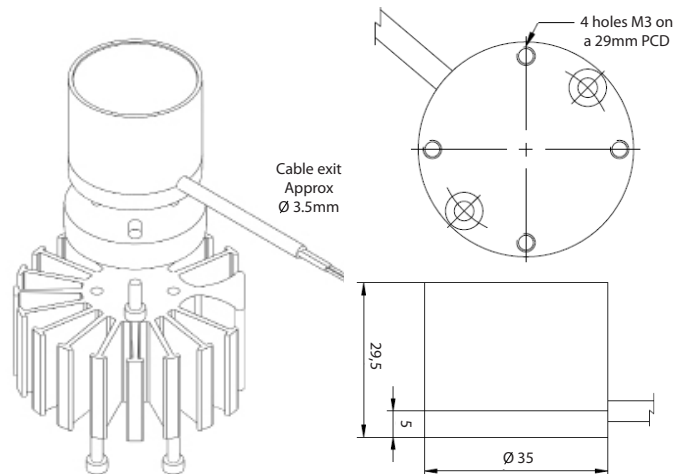

210214

For more information contact us at sales@prophotonix.com or visit us at www.prophotonix.com

LED Solutions

3020 Euro Business Park, Little Island
Cork, Ireland
Tel: +353-21-5001300

Lasers Solutions

Sparrow Lane, Hatfield Broad Oak
Hertfordshire, CM22 7BA, UK
Tel: +44-1279-717170

North/South America Sales

32 Hampshire Road
Salem, NH03079
Tel: +1 800-472-4633