

Basler aviator

AREA SCAN CAMERAS



- 1 to 4 megapixels and up to 120 fps
- Brilliant CCD color with 12 bit image quality
- High speed thanks to Kodak four tap sensor technology
- Outstanding performance

OVERVIEW

Fast Readout and Sensitivity

The Basler aviator family is a series of high speed mainstream CCD cameras with Gigabit Ethernet and Camera Link interface and a very attractive price/performance ratio. It features mono and color camera models with resolutions of 1, 2 (4:3 and HDTV), and 4 megapixels with progressive scan readout and global shutter technology.

Superior image quality, even at high image capture rates, makes a convincing argument for this advanced camera family. Basler aviator cameras are equipped with Kodak's latest CCD sensor generation with four tap readout technology. These sensors are up to four times faster than standard CCD sensors of the same resolution. With the aviator, Basler has applied the unique tap balancing competence we gained during the development of our earlier camera families such as the Basler pilot series, which also employs Kodak multi-tap sensors.



The Camera Link interface is the best way to integrate the full performance of the aviator's four tap Kodak sensors into your application with no bandwidth related delays. The Basler aviator GigE models benefit from our extensive experience designing and building GigE cameras and feature 100 meter cable length, easy integration and a cost-saving system layout.

Basler aviator cameras are an ideal fit for a variety of applications including semiconductor and electronics manufacturing, traffic applications (ITS), metrology, or medical imaging.

Your benefits include:

- Excellent linearity, dynamic range, and noise level
- The best tap balance by performing individual tap calibration during production
- More than 25 camera features such as auto-gain, auto-exposure or the signal input debouncer support easy system integration
- More than 100 megabytes of data per second and up to 100 meter cable length with GigE
- The widest bandwidth connection for maximum grabbing speed with Camera Link and compatibility with all common frame grabbers
- Additional opto-isolated I/Os for external devices (e.g., strobe) in the Camera Link models
- Rugged housing featuring safe locking connections and easy integration due to different mounting positions
- Field-proven Basler pylon driver package with both filter and performance drivers
- "GenICam over Camera Link" or direct register access support
- Very attractive price/performance ratio

TECHNICAL DETAILS



Specifications

Basler aviator	avA1000-100gm/gc	avA1600-50gm/gc	avA1900-50gm/gc	avA2300-25gm/gc
Camera				
Resolution (H x V pixels)	1024 x 1024	1600 x 1200	1920 x 1080	2330 x 1750
Sensor	Kodak KAI-01050	Kodak KAI-02050	Kodak KAI-02150	Kodak KAI-04050
Sensor Size (optical)	1/2"	2/3"	2/3"	1"
Sensor Technology	Progressive Scan CCD, global shutter			
Pixel Size	5.5 µm x 5.5 µm			
Frame Rate	101 fps	55 fps	51 fps	26 fps
Mono / Color	Mono / Color			
Video Output Format	Mono 8, Mono 12, Mono 12 Packed, YUV 4:2:2 Packed, YUV (4:2:2 (YUYV) Packed, Bayer GB 8, Bayer GB 12, Bayer GB 12 Packed			
Interface	Gigabit Ethernet (1000 Mbit/s)			
Synchronization	Via external trigger, via the Ethernet connection, or free-run			
Exposure Control	Via external trigger signal or programmable via the camera API			
Mechanical / Electrical				
Housing Size (L x W x H)	40.7 mm x 62 mm x 62 mm			
Housing Temperature	Up to 50 °C			
Lens Mount	C-mount			
Digital I/O	2 opto-isolated input / 4 opto-isolated output			
Power Requirements	12 VDC (±10%) via 12-pin Hirose connector			
Power Consumption (typical)	5.6 W	5.8 W	5.8 W	6.3 W
Weight (typical)	<300 g			
Conformity	CE, FCC, IP30, RoHS			
Software / Driver				
Driver	Basler pylon driver package			
Operating System	Windows, Linux - 32 bit and 64 bit			
Conformity	GigE Vision, GenICam			

Specifications are subject to change without prior notice.
 For detailed technical information, see the camera User's Manual that can be found at www.baslerweb.com/manuals

Dimensions (in mm)

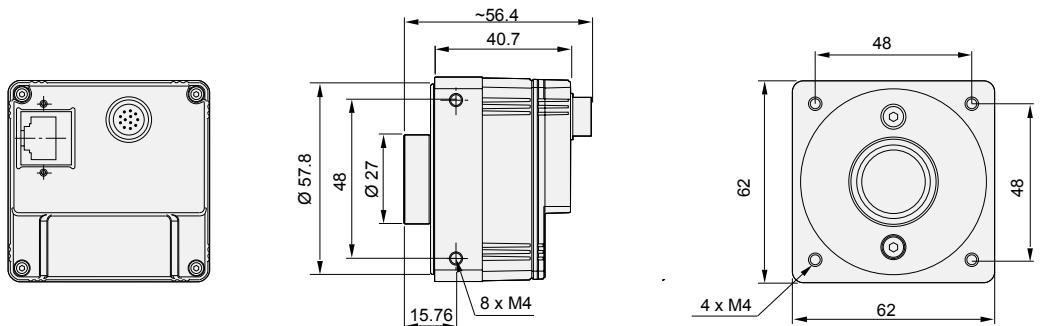

TECHNICAL DETAILS



Specifications

Basler aviator	avA1000-120km/kc	avA1600-65km/kc	avA1900-60km/kc	avA2300-30km/kc
Camera				
Resolution (H x V pixels)	1024 x 1024	1600 x 1200	1920 x 1080	2330 x 1750
Sensor	Kodak KAI-01050	Kodak KAI-02050	Kodak KAI-02150	Kodak KAI-04050
Sensor Size (optical)	1/2"	2/3"	2/3"	1"
Sensor Technology	Progressive Scan CCD, global shutter			
Pixel Size	5.5 µm x 5.5 µm			
Frame Rate	120 fps	67 fps	62 fps	31 fps
Mono / Color	Mono / Color			
Pixel Format	Mono 8, Mono 10, Mono 12, Bayer GR 8, Bayer GR10, Bayer GR12			
Interface	Camera Link (base), single 26-pin MDR connector			
CL Pixel Clock	32.5, 40, 48, or 65 MHz (selectable via software)			
CL Tap Geometry	1X2-1Y or 1X-2YE			
Synchronization	Via external trigger or free-run			
Exposure Control	Trigger width or timed			
Mechanical / Electrical				
Housing Size (L x W x H)	41.2 mm x 62 mm x 62 mm			
Housing Temperature	Up to 50 °C			
Lens Mount	C-mount			
I/O Ports	2 opto-isolated input / 1 opto-isolated output			
Power Requirements	12 VDC (±10%) via 6-pin Hirose connector			
Power Consumption (typical)	5.0 W	5.5 W	5.5 W	6.0 W
Weight (typical)	<300 g			
Conformity	CE, FCC, IP30, RoHS			
Software Environment				
Configuration Software	Basler pylon release 2.2 or higher			
API for Configuration	Register API for C and VB6 or Basler pylon C++ API			
Conformity	Camera Link, GenICam			

Specifications are subject to change without prior notice.

For detailed technical information, see the camera User's Manual that can be found at www.baslerweb.com/manuals

Dimensions (in mm)

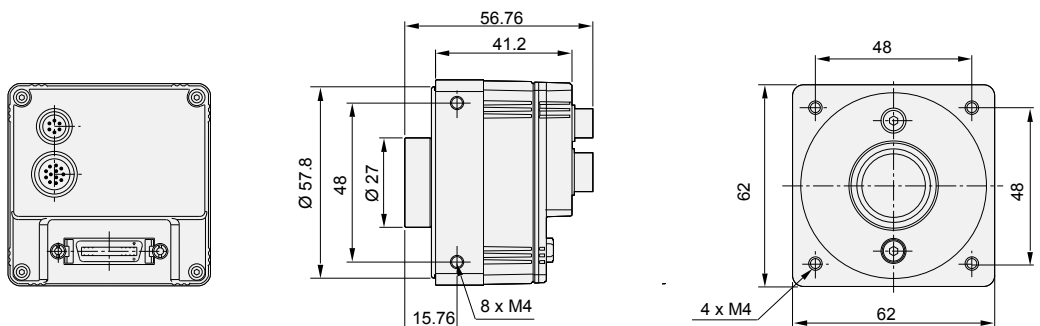

Get your free version:
www.baslerweb.com/pylon

Basler pylon Driver Package

The pylon driver package operates with all Basler line scan and area scan cameras. It offers stable, reliable and flexible data exchange between Basler cameras and PCs, at a very low CPU load.

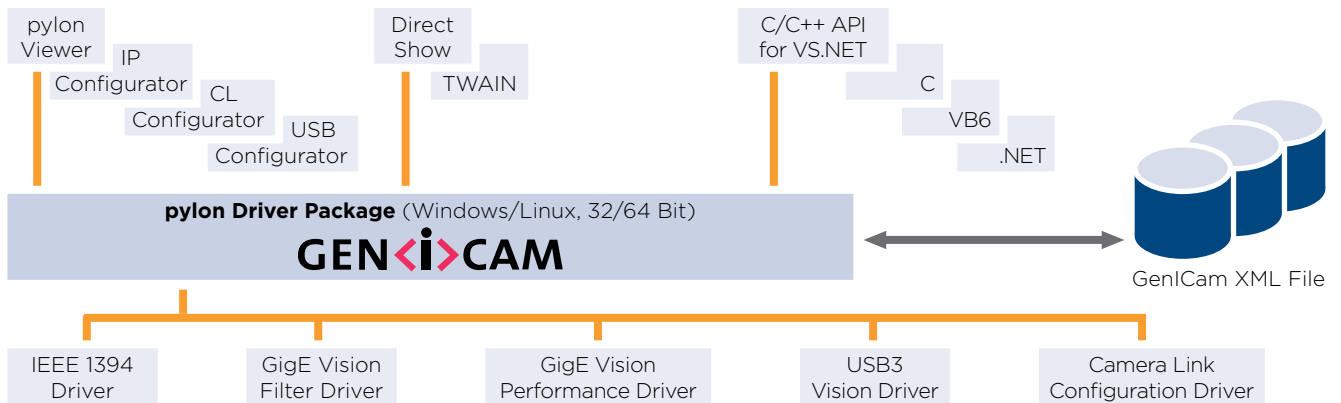

The internal architecture of the pylon driver package is based on GenICam Technology, which offers you easy access to the newest camera models and the latest features. Changes to an existing camera device in your application essentially become a plug-and-play process.

The pylon **USB3 Vision Driver** fully supports the USB3 Vision standard. It allows Basler USB 3.0 cameras to use the full speed and bandwidth of USB 3.0 for image transmission while reducing resource load and using off-the-shelf hardware components.

The pylon **GigE Vision Performance Driver** quickly separates incoming packets carrying image data from other traffic on the network and makes the data available for use by your vision application while requiring the lowest CPU resources. This driver can only be used with network cards that include specific Intel chipsets. The pylon **GigE Vision Filter Driver** supports all kinds of hardware, common GigE network cards, and GigE ports on your motherboard as well.

The pylon **IEEE 1394b Driver** gives you access to a well-established interface technology, and the pylon **Camera Link Configuration Driver** offers comfortable access to all camera parameters of Basler's latest Camera Link families ace, aviator, and racer.

The pylon Viewer offers you a convenient application for testing and evaluating Basler cameras. The pylon SDK supports any type of application development. The pylon package contains the following main modules. Each one can be individually selected/unselected during the installation process, preventing the installation of unneeded modules on your system.

- USB3 Vision Driver
- GigE Vision Filter Driver
- GigE Vision Performance Driver
- IEEE 1394 Driver
- Camera Link Serial Communication Driver
- pylon Viewer
- pylon SDK for all cameras; C, C++, .NET (C#, VB.NET, ...), and VB6 (the 'pylon for Linux' version only supports the GigE interface via a C++ API)

The pylon driver package can be downloaded for free at www.baslerweb.com/pylon. For more information on the installation process, refer to the pylon Installation Guide. The helpful pylon Release Notes contain all improvements and bug fixes since the first pylon version.

OTHER INFORMATION

How Does Basler Measure and Define Image Quality?



Basler is leading the effort to standardize image quality and sensitivity measurement for cameras and sensors. We are giving the EMVA 1288 standard our strongest support because it describes a unified method to measure, compute, and present the specification parameters for cameras and image sensors. Our cameras are characterized and measured in 100% compliance with the EMVA 1288 standard. Measurement reports can be downloaded from our website.

How Does Basler Ensure Superior Quality and Reliable High Performance?

Our approach to quality assurance is rigorous: we continually audit all facets of our business to guarantee performance, increase efficiency and reduce costs for our customers. We are compliant with all major quality standards including ISO9001, CE, RoHS, and more. To ensure consistently high product quality, we employ several quality inspection procedures during manufacturing.

Every Basler camera is subjected to exhaustive optical and mechanical tests before leaving the factory. We have developed a unique combination of optics, hardware, and software tools that can quickly and efficiently calibrate a camera and measure its performance against a set of standard performance criteria. Regardless of what technology or camera model you choose you can be assured of consistent performance.

3-Year Warranty

Basler offers a 3-year warranty for our cameras. We make this unprecedented promise because we have unparalleled confidence in our products. We continually reinvest in research, development and superior manufacturing capabilities so that our customers can fully rely on the products we manufacture.

About Basler

Founded in 1988, Basler is a leading global manufacturer of high quality digital cameras for industrial, medical, traffic and video surveillance applications. The company employs some 300 people at its headquarters in Ahrensburg, Germany and subsidiaries in the United States and Asia.

Basler's portfolio of products offers customers the vision industry's widest selection of industrial and network cameras. Today it includes some 300 models - and it's still growing. We're committed to developing technology that drives business results for our customers: cameras that are easy to use, easy to integrate, and deliver an exceptional price/performance ratio.



© 10/2012

Basler AG

Germany, Headquarters

Tel. +49 4102 463 500

Fax +49 4102 463 599

sales.europe@baslerweb.com

www.baslerweb.com

USA

Tel. +1 610 280 0171

Fax +1 610 280 7608

sales.usa@baslerweb.com

Singapore

Tel. +65 6425 0472

Fax +65 6425 0473

sales.asia@baslerweb.com

Korea

Tel. +82 707 1363 114

Fax +82 707 0162 705

sales.korea@baslerweb.com

BASLER
the power of sight