

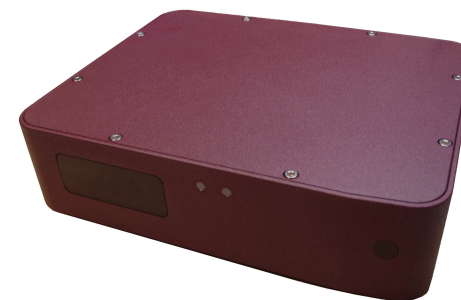

# Specifications: ODS Red-Line 1 kHz series

2, 5 & 10 kHz versions of all ODS Red-Line models are available.



Select Models :	ODS 505	ODS 500-1100	ODS 925	ODS 1150	ODS 1950	ODS 1400	ODS 3000
<b>High &amp; Very High Target Temperature</b>	+	+	+	+	+	+	+
<b>Measurement data:</b>							
Measuring range	100 mm	200 mm	650 mm	900 mm	900 mm	1400 mm	2000 mm
Measuring range	450–550 mm	Center ± 100 mm	600–1250 mm	700–1600 mm	1500-2400 mm	700-2100 mm	2000-4000 mm
Center distance (mm)	500 mm	500, 700, 950 & 1100	925 mm	1150 mm	1950 mm	1400 mm	3000 mm
Resolution *)	0.01 mm	0.05 mm	0.1 mm	0.1 mm	0.2 mm	0.3 mm	0.5 mm
Reproducibility*)	±Resolution	±Resolution	±Resolution	±Resolution	±Resolution	±Resolution	±Resolution
Linearity *)	±0.05 mm	±0.10 mm	±0,3 mm	±0.4 mm	±0.5 mm	±0.7 mm	±1.0 mm
Updating frequency	1 kHz	1 kHz	1 kHz	1 kHz	1 kHz	1 kHz	1 kHz
Temperature deviation	±0.03% FS/C°	±0.03% FS/C°	±0.03% FS/C°	±0.03% FS/C°	±0.03% FS/C°	±0.03% FS/C°	±0.03% FS/C°
Light source ( nm )	LASER (655)	LASER (655)	LASER (655)	LASER (655)	LASER (655)	LASER (655)	LASER (655)
Size of spot	App. Ø 1 mm	Ø 2-3 mm	Ø 4 mm	Ø 4 mm	Ø 5 mm	Ø 5 mm	Ø 5 mm
Laser protection class	IEC 2	IEC 2	IEC 2	IEC 2	IEC 2	IEC 2	IEC 2
<b>Output data:</b>		<b>Electrical data:</b>		<b>Environment data:</b>		<b>Physical data:</b>	
Analog output **):	4-20 mA or 1-9 V DC	Supply voltage	22 - 36 VDC	Operating temperature	0 - +45 C°	Dimensions	255*70*205 mm
Digital output **):	RS232 or RS422	Power consumption	max 4.5 W	Storage temperature	-20 - +70 C°	Weight excl. Cable	4.5 Kg
Ethernet output †):	Alternative to RS output			Humidity non condensing	Max 90 % RH	Cable length	2.5 m
Baud rate: 38400:	1 kHz output frequency			Degree of protection	IEC IP65	Housing	Aluminum / Glass

\*) Static measurement on white paper at measuring frequency of 1 kHz, without any averaging of the output signals. Sampling and output frequency being equal.

\*) Data are for digital as well as analog outputs, because 14 Bit DAC's are used for the conversion.

\*\*\*) The serial/digital and analog outputs are updated at the measuring frequency of 1 kHz except if the Simple Average Filter is set to be active.

†) The Ethernet interface can be used for distance measurement only, i.e. connection for sensor internal thickness or difference measurement is not available.

**More information on back page >**

July 2010; Subject to change without notice.

**Columbusvej 3 • DK-2860 Søborg • Denmark • Tel: +45 39 66 71 44 • Fax: +45 39 66 71 45 • E-mail: dse@sensor.dk**

## Measuring frequency 1 kHz

Output rates are user specified, as the sensor can be programmed to make an average of up to 200 measurements (disregarding all zero/missing values) and output it as a single point. In this way the output rate can be lowered from 1000 kHz in steps down to 5 Hz. This is done with the Simple Average Filter.

All ODS Red-Line sensors have a programming /Select functionality. Group Mode is the main feature. In Group Mode a running average is calculated over a user specified number of measuring points. The user also programs the sensor to disregard a number of, usually all, bad (zero) measuring points before calculating the average value. The average values are calculated at full measuring frequency and are used for converting the analog signal. Several Median filters and other options like Level Mode are available.

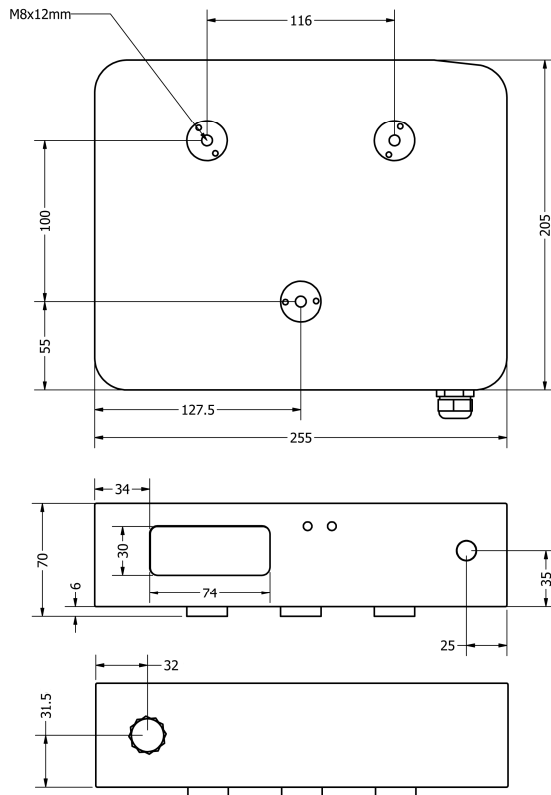

## ODS Thickness Measurement

ODS Red-Line sensors are calibrated for measuring thickness when paired.

All ODS Red-Line sensors will automatically turn itself into being either the Master or the Slave half part of a thickness measuring system when connected to an identical ODS sensor model.

The Master sensor reads the digital distance data send from the Slave sensor over their RS232 or RS422 serial interface, and after taking its own distance information into account, it will output the change in thickness in its calculated digital form as well as a converted analog signal. The sensors must be synchronized and will measure on transparent targets alternately from one side if they are wired to measure at 500 Hz (half) frequency.

A couple of ODS sensors will thus measure thickness or width without any control box or special calibration from the factory. Two ODS sensors can be programmed to operate in difference Mode instead of measuring thickness. This unique characteristic of the ODS meters are available in all compatible versions in the Red-Line range of models, also HT models.

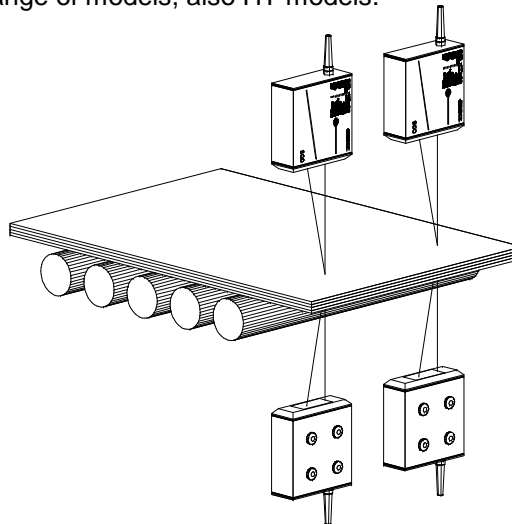

## ODS High Temperature models

The HT models are designed for target surfaces temperatures up to 1000°C.

The VHT models are designed for surface temperatures up to 1300°C, and the VVHT models are designed for surface temperatures up to 2.200°C using a BLUE laser diode.

Because of the non-contact measurement method, the ODS Select-x HT sensors are specially designed for measurement on objects that are more than 450 °C hot like hot rolled steel or molten metals and glass. Laser class 2 sensors achieve target temperature up to 1000°C in HT form. VHT models can in laser class 3R form reach target temperatures of generally up to 1300°C, and in 3B form even higher. For surfaces with mirror type properties a sensor with laser class 3B can also be needed.

All the models in the 1 kHz ODS Red-Line family can be delivered in HT, VHT & VVHT specification and some in 2, 5 and 10 kHz form.

It is important to stress, that the HT specification only concerns the target temperature. Maximum allowed sensor environment temperature is 45 °C.

The HT specification can also be necessary when there is a high risk of harmful false light as is the case with sunlight, both direct and reflected.

