

## MV1-D2080-160-G2

The camera series MV1-D2080(IE)-G2 is based on the Photonfocus A2080 and A2080IE CMOS image sensors with LinLog® technology

### Features

- Photonfocus A2080 CMOS image sensor
- 2080 x 2080 pixel resolution
- Good NIR spectral response
- Exceptional SNR up to 300: 1
- Dynamic range up to 120dB via LinLog®
- Up to 25fps @ full resolution
- Global shutter
- Available in monochrome, enhanced NIR
- Extended sensor and camera features
- Up to 12bit greyscale resolution
- Boardlevel and OEM solution available
- GigEVision interface



## Quantum Efficiency Image Sensor

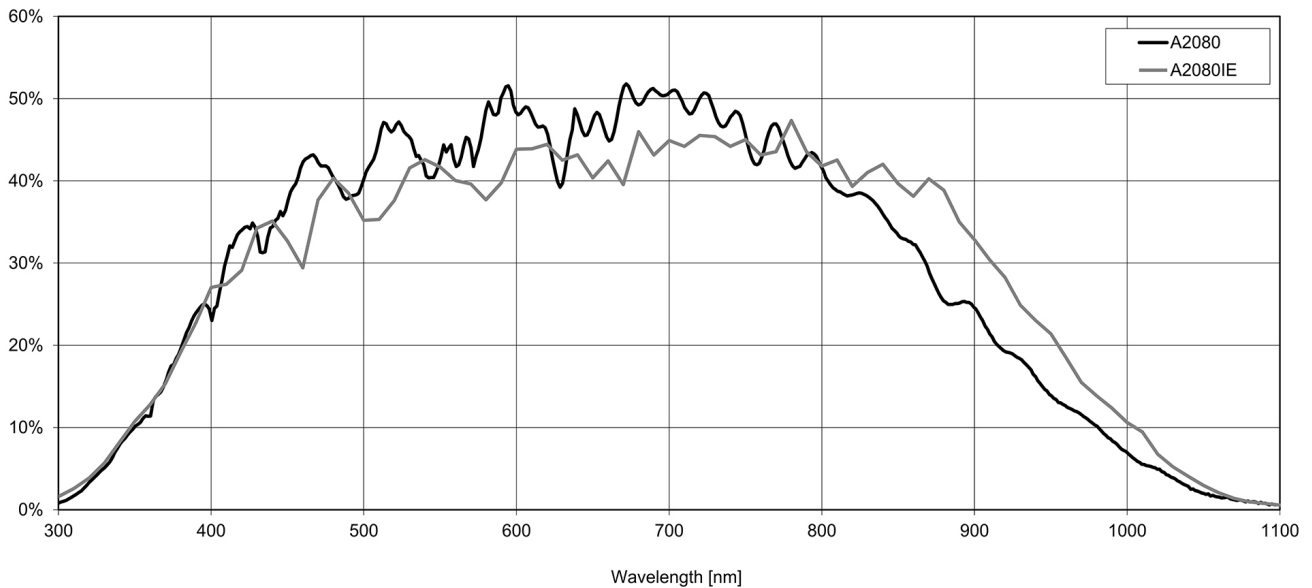

## Image Sensor Specifications

Manufacturer / Type	Photonfocus / A2080	
Technology	CMOS	
Optical format	4/3"	
Optical diagonal	25.5mm	
Resolution	2080 x 2080	
Pixel size	8µm x 8µm	
Active optical area	16.64mm x 16.64mm	
Dark current	4000e <sup>-</sup> /s	
Read out noise	110e <sup>-</sup>	
Full well capacity / SNR	90ke <sup>-</sup> / 300: 1	
Spectral range	Monochrome:	< 350 to 980nm (to 10% of peak responsivity)
	NIR Enhanced:	< 320 to 1000nm (to 10% of peak responsivity)
Responsivity	Monochrome:	295 x 10 <sup>3</sup> DN / (J/m <sup>2</sup> ) @ 670nm / 8bit
	NIR Enhanced:	305 x 10 <sup>3</sup> DN / (J/m <sup>2</sup> ) @ 850nm / 8bit
Quantum Efficiency	Monochrome:	> 50%
	NIR Enhanced:	> 50%
Optical fill factor	> 60%	
Dynamic range	60dB in linear mode; 120dB with LinLog®	
Characteristic curve	Linear, LinLog®	
Shutter mode	Global Shutter	

## Camera Specifications

Interface	GigE
Frame rate	25fps
Pixel clock	80MHz
Camera taps	2
Greyscale resolution	8Bit / 10Bit / 12Bit
Fixed pattern noise (FPN)	< 1DN RMS @ 8Bit
Exposure time range	10µs - 419ms
Analog gain	n/a
Digital gain	0.1 to 15.99 (FineGain)
Trigger Modes	Free running (non triggered), external Trigger, SWTrigger
Features	Configurable region of interest (ROI), Up to 512 regions of interest (MROI), Decimation in y-direction, Image correction, 2 look-up tables (12-to-8Bit) on user-defined image region (Region-LUT), Constant frame rate independent of exposure time, Crosshairs overlay on the image, 3x3 convolver for image preProcessing, Temperature monitoring of sensor and camera, Camera informations readable over SDK, Ultra low trigger delay and low trigger jitter, Extended trigger input and strobe output functionality, Status line in picture
Operation temperature / moisture	0°C ... + 50°C / 20% ... 80%
Storage temperature / moisture	-25°C ... 60°C / 20% ... 95%
Power supply	+12VDC (-10%) ... +24VDC (+10%)
Power consumption	< 5.2W
Lens mount	M42x1, F-Mount, C-Mount 1.3"
I/O Inputs	2x Opto-isolated 2x RS-422 Opto-isolated
I/O Outputs	2x Opto-isolated
Dimensions	60 x 60 x 47mm <sup>3</sup>
Mass	294g
Connector I/O (Power)	Hirose 12-pole (mating plug HR10A-10P-12S)
Connector Interface	RJ-45
Conformity	CE / RoHS / WEEE
IP Code	IP20

## Connectors

Pin	I/O Type	Name	Description
1	PWR	CAMERA_GND	Camera GND 0V
2	PWR	CAMERA_PWR	Camera Power 12V... 24V
3	O	ISO_OUT0	Default Strobe out, internally Pulled up to ISO_PWR with 4k7 Resistor
4	I	ISO_INC0_N	INC0 differential input (G2: RS-422, H2: HTL), negative polarity
5	I	ISO_INC0_P	INC0 differential input (G2: RS-422, H2: HTL), positive polarity
6	PWR	ISO_PWR	Power supply 5V... 24V for output signals
7	I	ISO_IN0	IN0 input signal
8	O	ISO_OUT1 (MISC)	Q1 output from PLC, no Pull up to ISO_PWR; can be used as additional output (by adding Pull up) or as controllable switch (max. 100mA, no capacitive or inductive load)
9	I	ISO_IN1(Trigger IN)	Default Trigger IN
10	I	ISO_INC1_N	INC1 differential input (G2: RS-422, H2: HTL), negative polarity
11	I	ISO_INC1_P	INC1 differential input (G2: RS-422, H2: HTL), positive polarity
12	PWR	ISO_GND	I/O GND 0V

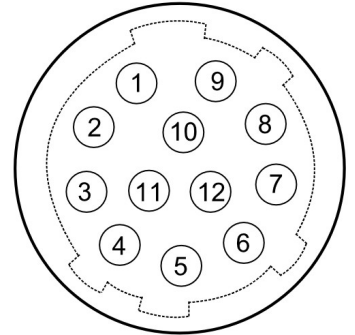

## Dimensions

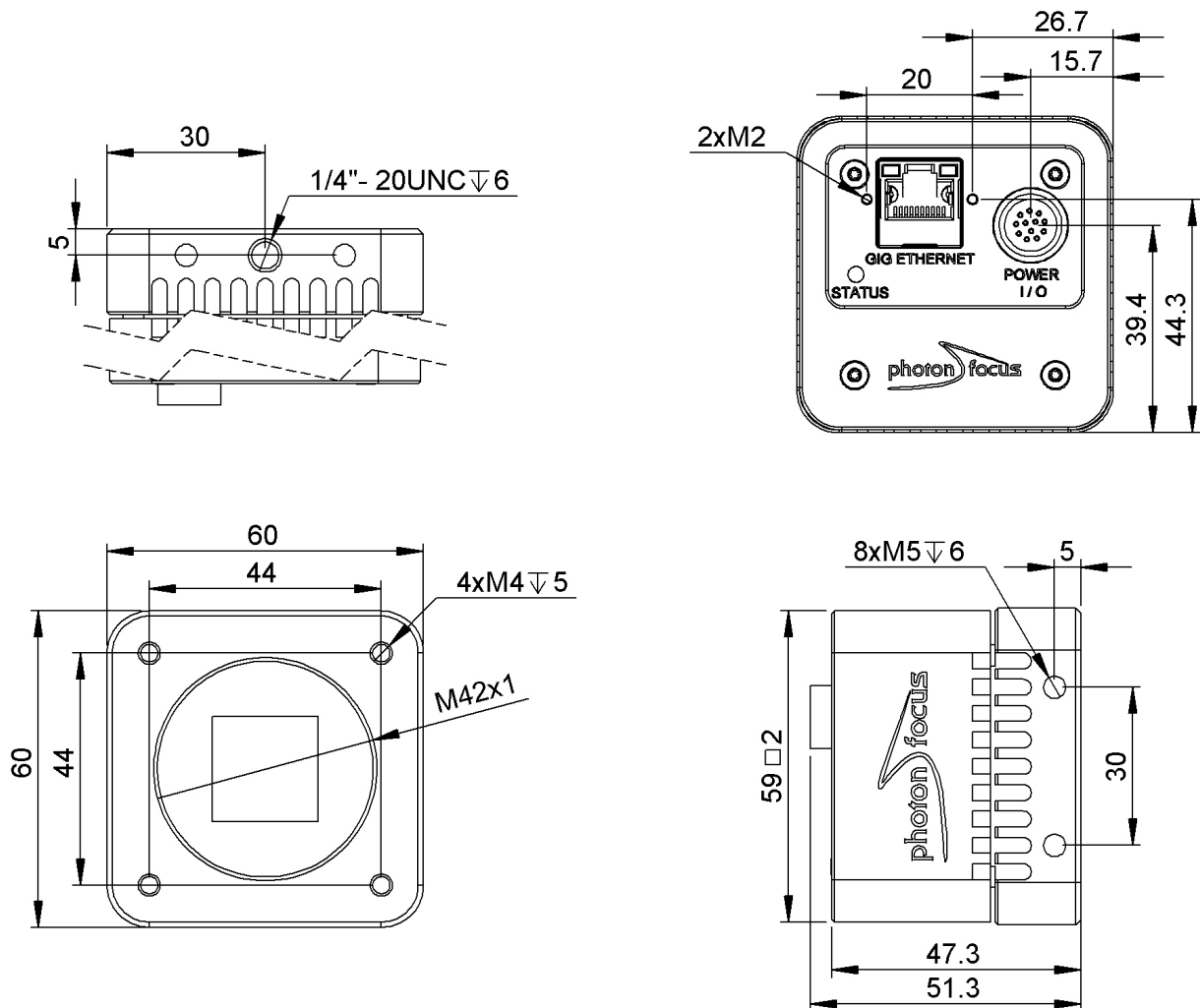

## Explanation

DN	DigitalNumber (equals to LSB)
e <sup>-</sup>	Electrons

## Order Information

MV1-D2080-160-G2-12-42	BW model (M42)
MV1-D2080-160-G2-12-CM	BW model (C-Mount)
MV1-D2080-160-G2-12-FM	BW model (F-Mount)
MV1-D2080IE-160-G2-12-42	NIR-Enhanced model (M42)
MV1-D2080IE-160-G2-12-CM	NIR-Enhanced model (C-Mount)
MV1-D2080IE-160-G2-12-FM	NIR-Enhanced model (F-Mount)

## Compatibility



**Photonfocus AG**  
Bahnhofplatz 10  
CH-8853 Lachen SZ  
Switzerland

Phone: +41 55 451 00 00  
[www.photonfocus.com](http://www.photonfocus.com)  
[info@photonfocus.com](mailto:info@photonfocus.com)