

MV1-D1024E-3D02-160-G2

The CMOS camera MV1-D1024E-3D02-160-G2 was developed for laser triangulation of highly reflective materials

Features

- Detection of a laser line with sub-pixel accuracy
- Photonfocus A1024B CMOS image sensor
- 1024 x 1024 pixel resolution
- Exceptional SNR up to 447: 1
- Dynamic range up to 120dB via LinLog®
- Up to 6750fps @ 1024x20 pixels
- Global shutter
- Monochrome
- Extended sensor and camera features
- Reduction of ROI in x- and y-direction increases frame rate
- A/B shaft encoder interface
- GigEVision interface
- Free GUI available (PF 3D Suite)



Quantum Efficiency Image Sensor

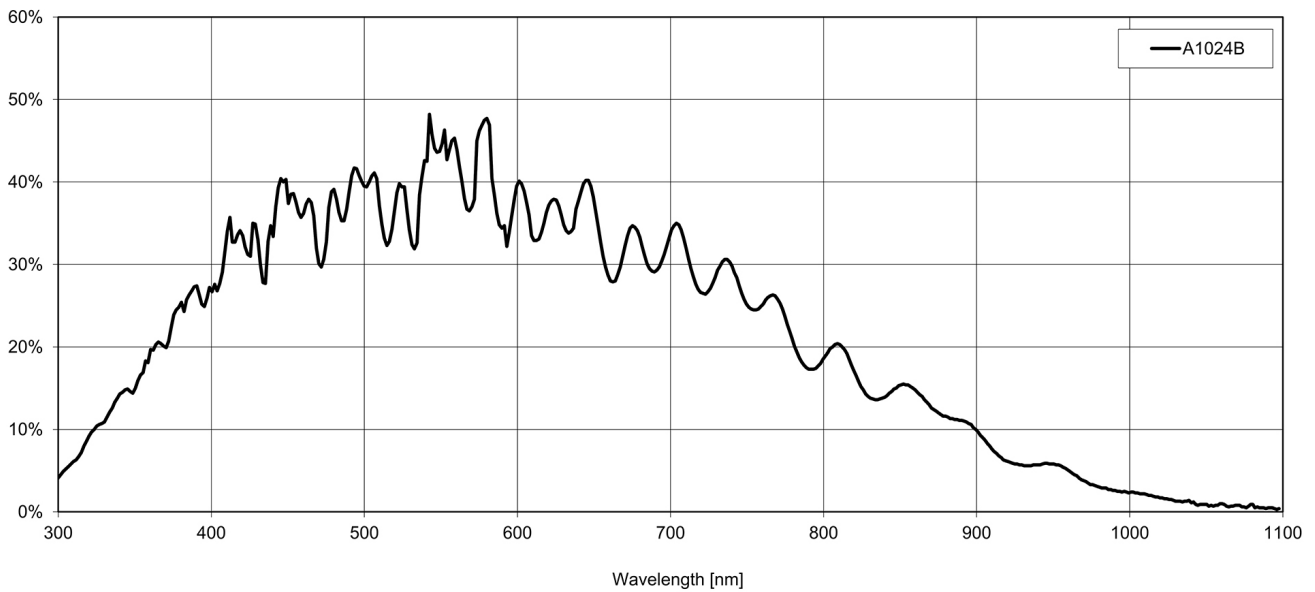

Image Sensor Specifications

Manufacturer / Type	Photonfocus / A1024
Technology	CMOS
Optical format	1"
Optical diagonal	15.42mm
Resolution	1024 x 1024
Pixel size	10.6µm x 10.6µm
Active optical area	10.9mm x 10.9mm
Dark current	107'000e ⁻ /s
Read out noise	220e ⁻
Full well capacity / SNR	200ke ⁻ / 447: 1
Spectral range	Monochrome: < 400 to 900nm (to 10% of peak responsivity)
Responsivity	Monochrome: 120 x 10 ³ DN / (J/m ²) @ 610nm / 8bit
Quantum Efficiency	Monochrome: > 45%
Optical fill factor	35%
Dynamic range	60dB in linear mode; 120dB with LinLog®
Characteristic curve	Linear, LinLog®, Skimming
Shutter mode	Global shutter

Camera Specifications

Interface	GigE
Frame rate	6750fps
Pixel clock	80MHz
Camera taps	2
Greyscale resolution	8Bit
Fixed pattern noise (FPN)	< 1DN RMS @ 8bit
Exposure time range	10µs - 419ms
Analog gain	n/a
Digital gain	0.1 to 15.99 (FineGain)
Trigger Modes	Free running (non triggered), external Trigger, SWTrigger, AB-Trigger
Features	Detection of a laser line (peak detector) with sub-pixel accuracy, Configurable region of interest (ROI), Dynamic range up to 120dB via LinLog®, Image correction, Ultra low trigger delay and low trigger jitter, Extended trigger input and strobe output functionality, Isolated inputs (2 single ended, 2 differential) and outputs (2 single ended), A/B shaft encoder interface (RS-422 (G2 models) or HTL (H2 models)), Free GUI available (PF 3D Suite) for an easy system set up and visualisation of 3D scans
Operation temperature / moisture	0°C ... + 50°C / 20% ... 80%
Storage temperature / moisture	-25°C ... 60°C / 20% ... 95%
Power supply	+12VDC (-10%) ... +24VDC (+10%)
Power consumption	< 4.8W
Lens mount	C-Mount (CS-Mount optional)
I/O Inputs	2x Opto-isolated 2x RS-422 or HTL Opto-isolated for AB-Trigger
I/O Outputs	2x Opto-isolated
Dimensions	55 x 55 x 49mm ³
Mass	260g
Connector I/O (Power)	Hirose 12-pole (mating plug HR10A-10P-12S)
Connector Interface	RJ-45
Conformity	CE / RoHS / WEEE
IP Code	IP20

Connectors

Pin	I/O Type	Name	Description
1	PWR	CAMERA_GND	Camera GND 0V
2	PWR	CAMERA_PWR	Camera Power 12V... 24V
3	O	ISO_OUT0	Default Strobe out, internally Pulled up to ISO_PWR with 4k7 Resistor
4	I	ISO_INC0_N	INC0 differential input (G2: RS-422, H2: HTL), negative polarity
5	I	ISO_INC0_P	INC0 differential input (G2: RS-422, H2: HTL), positive polarity
6	PWR	ISO_PWR	Power supply 5V... 24V for output signals
7	I	ISO_IN0	IN0 input signal
8	O	ISO_OUT1 (MISC)	Q1 output from PLC, no Pull up to ISO_PWR; can be used as additional output (by adding Pull up) or as controllable switch (max. 100mA, no capacitive or inductive load)
9	I	ISO_IN1(Trigger IN)	Default Trigger IN
10	I	ISO_INC1_N	INC1 differential input (G2: RS-422, H2: HTL), negative polarity
11	I	ISO_INC1_P	INC1 differential input (G2: RS-422, H2: HTL), positive polarity
12	PWR	ISO_GND	I/O GND 0V

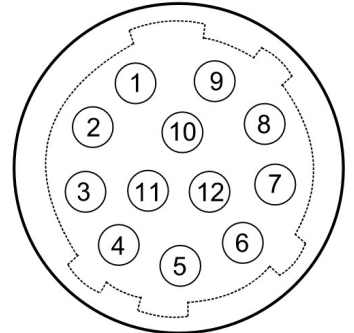

Dimensions

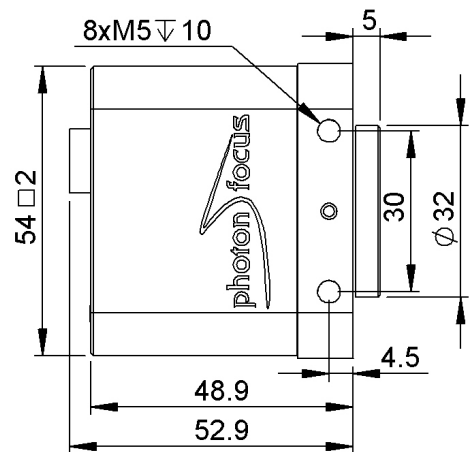
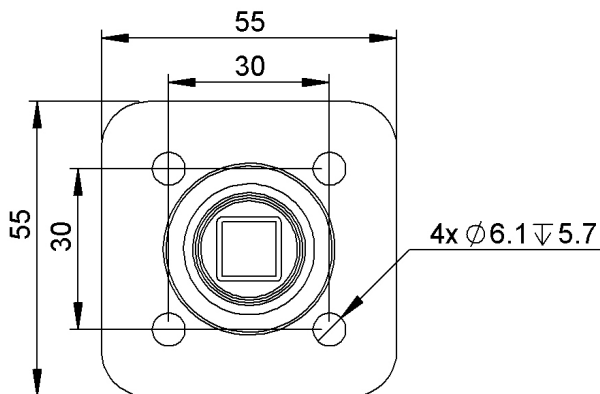
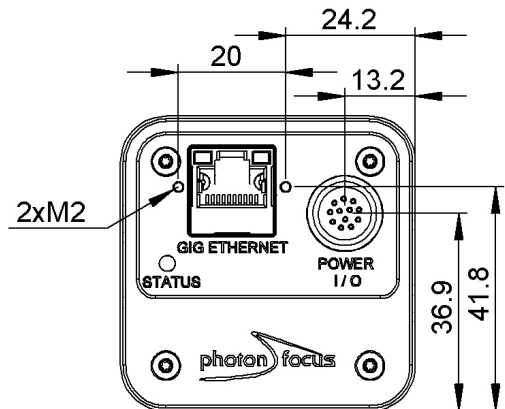
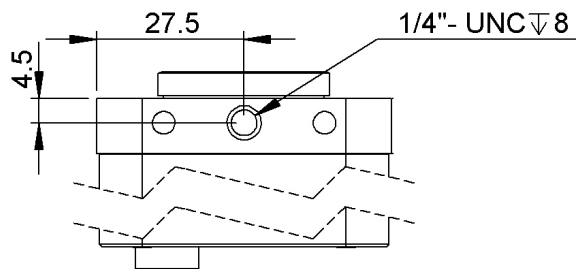

Explanation

DN	DigitalNumber (equals to LSB)
e ⁻	Electrons

Order Information

MV1-D1024E-3D02-160-G2-8	RS-422 Encoder Interface
--------------------------	--------------------------

Compatibility



Photonfocus AG
Bahnhofplatz 10
CH-8853 Lachen SZ
Switzerland

Phone: +41 55 451 00 00
www.photonfocus.com
info@photonfocus.com